

オプション品E388673とE044162を用いた場合

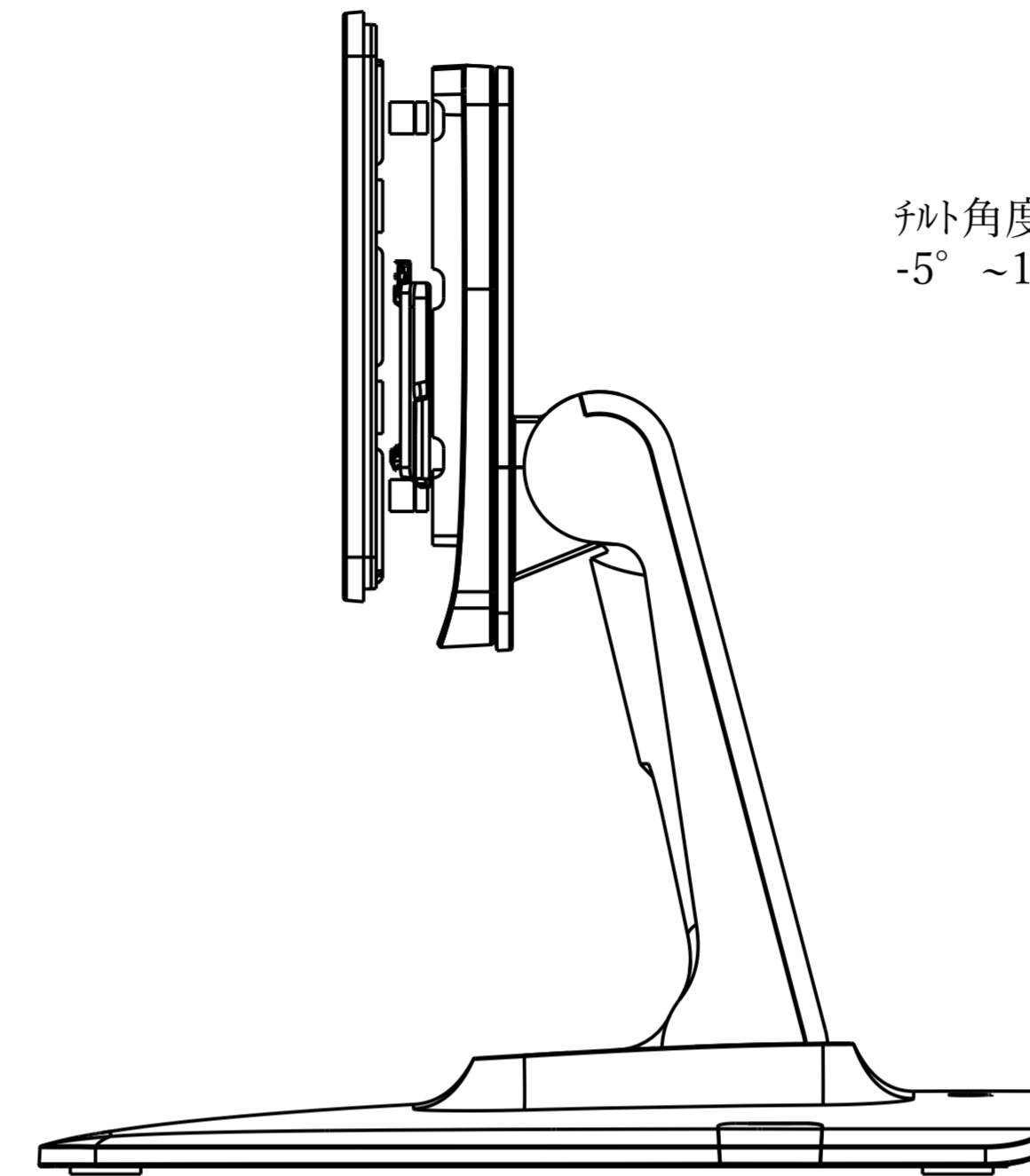

チルト角度調整範囲  
-5° ~150°

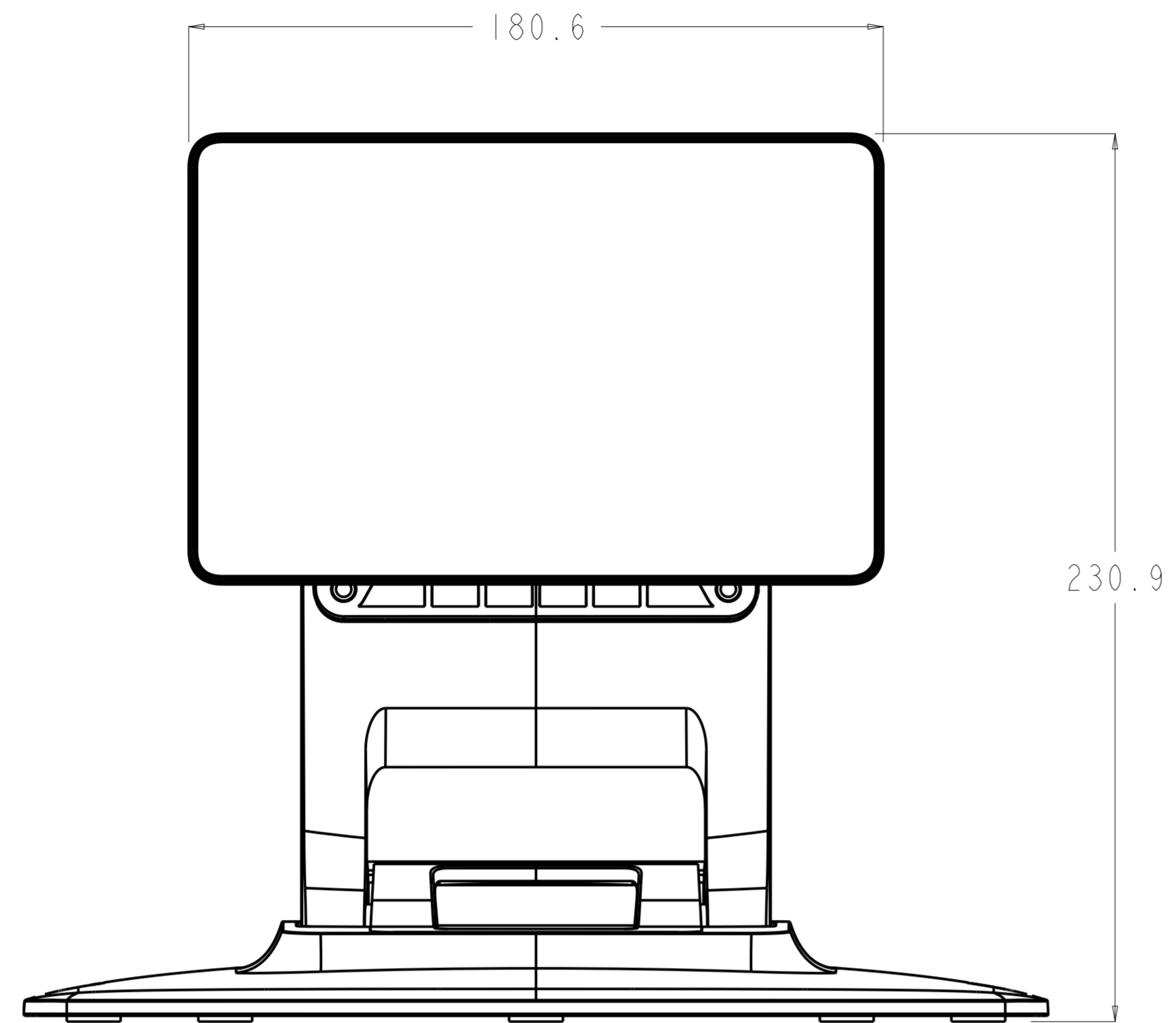